

QUICK START

1. VERIFICACIÓN PARA ELEGIR EL TIPO DEL DISPOSITIVO.



ATENCIÓN



OBSERVAR



OSCILOSCOPIO



MANUAL

SEÑAL DEL SENSOR DEL CIGÜEÑAL

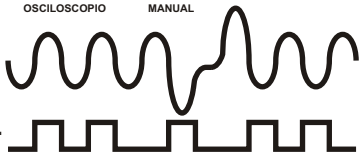

→ TAP-03/1

→ TAP-03/2

SEÑAL DEL SENSOR DEL ÁRBOL DE LEVAS

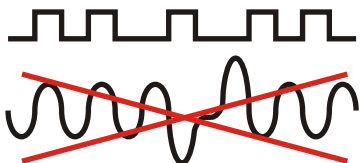

→ TAP-03/1/
TAP-03/2

2. EL SISTEMA DE ENCENDIDO VERIFICACIÓN



ATENCIÓN



OBSERVAR



BUJÍAS, CABLES DE ENCENDIDO

3. VERIFICACIÓN DE ENSAMBLAJE DEL DISPOSITIVO.

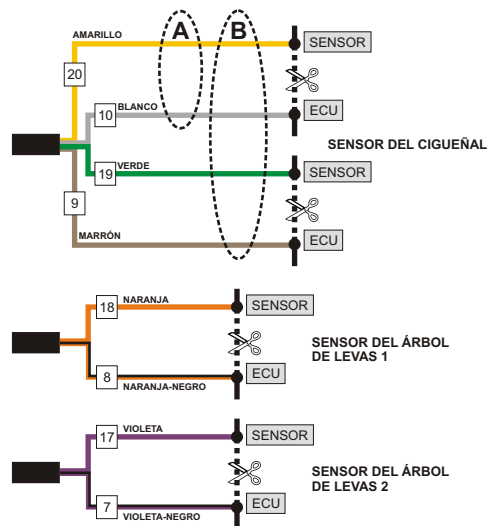
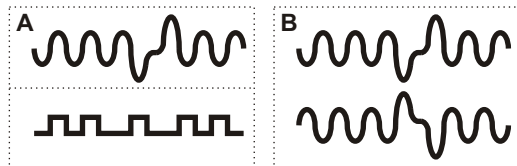
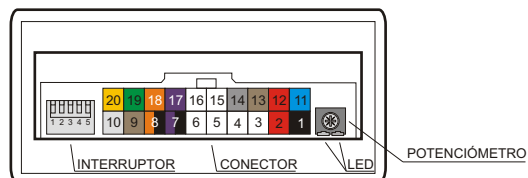
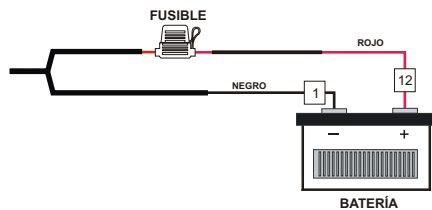

4. SELECCIÓN DEL TIPO DE LA AUTO CALIBRACIÓN.

MANUALMENTE



AJUSTE INTERRUPTOR NO. 4



A) ENCIENDA EL MOTOR



B) DEJE EL MOTOR EN GASOLINA

C) APAGUE EL AIRE ACONDICIONADO Y ESPERE HASTA QUE EL MOTOR ESTÉ CALIENTE



D) BAJE EL INTERRUPTOR NO. 5



E) EL LED VERDE ESTÁ TITILANDO



F) ESPERE



G) EL LED NO ALUMBRA - EL FIN DE LA AUTO CALIBRACIÓN

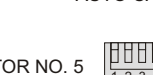

H) SUBA EL INTERRUPTOR NO. 5

USANDO LA COMPUTADORA



AJUSTE INTERRUPTOR NO. 4



A) ENCIENDA EL MOTOR



B) DEJE EL MOTOR EN GASOLINA

C) APAGUE EL AIRE ACONDICIONADO Y ESPERE HASTA QUE EL MOTOR ESTE CALIENTE



D) ELIJA EL TIPO DE COMBUSTIBLE



E) PULSE EL BOTÓN **START** PARA INICIAR LA AUTO CALIBRACIÓN

F) ESPERE



G) **100%** - EL FIN DE LA AUTO CALIBRACIÓN



5. AJUSTES

MANUALMENTE



A) CONFIGURACIÓN DE TIEMPO DE AVANCE DE ENCENDIDO

6°



10°



8°



12°



B) CONFIGURACIÓN DEL SENSOR DE MAP/MAF/TPS

- CRECIENTE



- DECRECIENTE



C) CONFIGURACIÓN DEL RALENTÍ

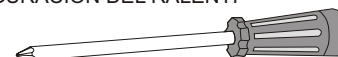

USANDO UN COMPUTADOR



6. PROBLEMAS

1.



- INSTRUCCIÓN

2.



- tel.: +48 857 438 154

3.



- www.ac.com.pl